

# Plan du cours

---

La théorie des perturbations : rappel

Un exemple : le propène

La réactivité : modélisation

Application aux cycloadditions

# Perturbations

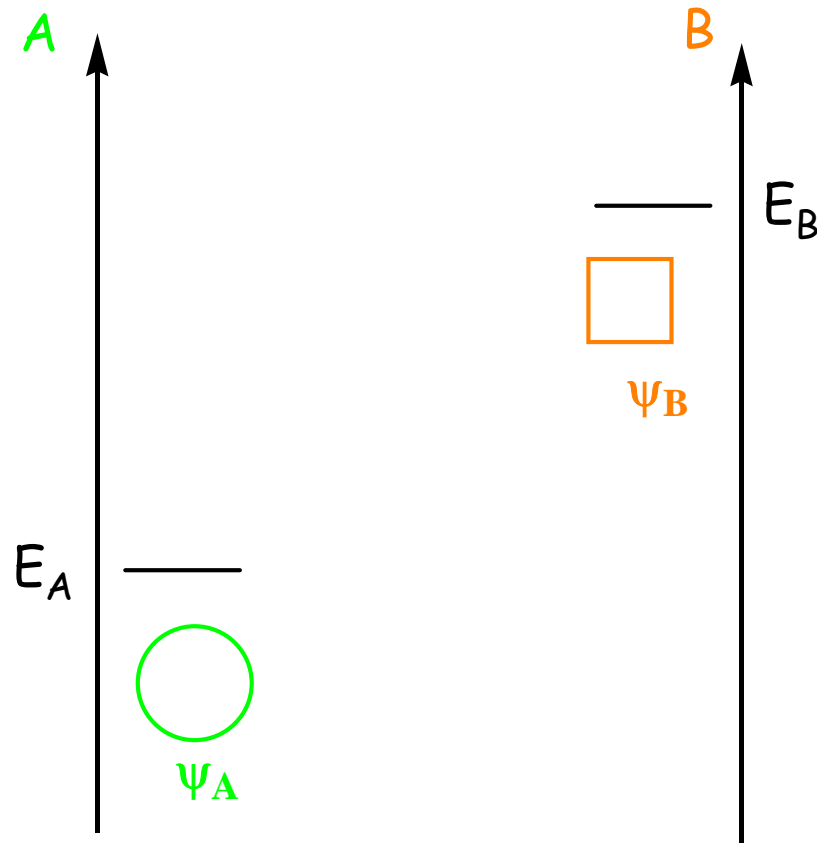

Construction rapide du nouveau système A-B

# Cas de deux OM dégénérées

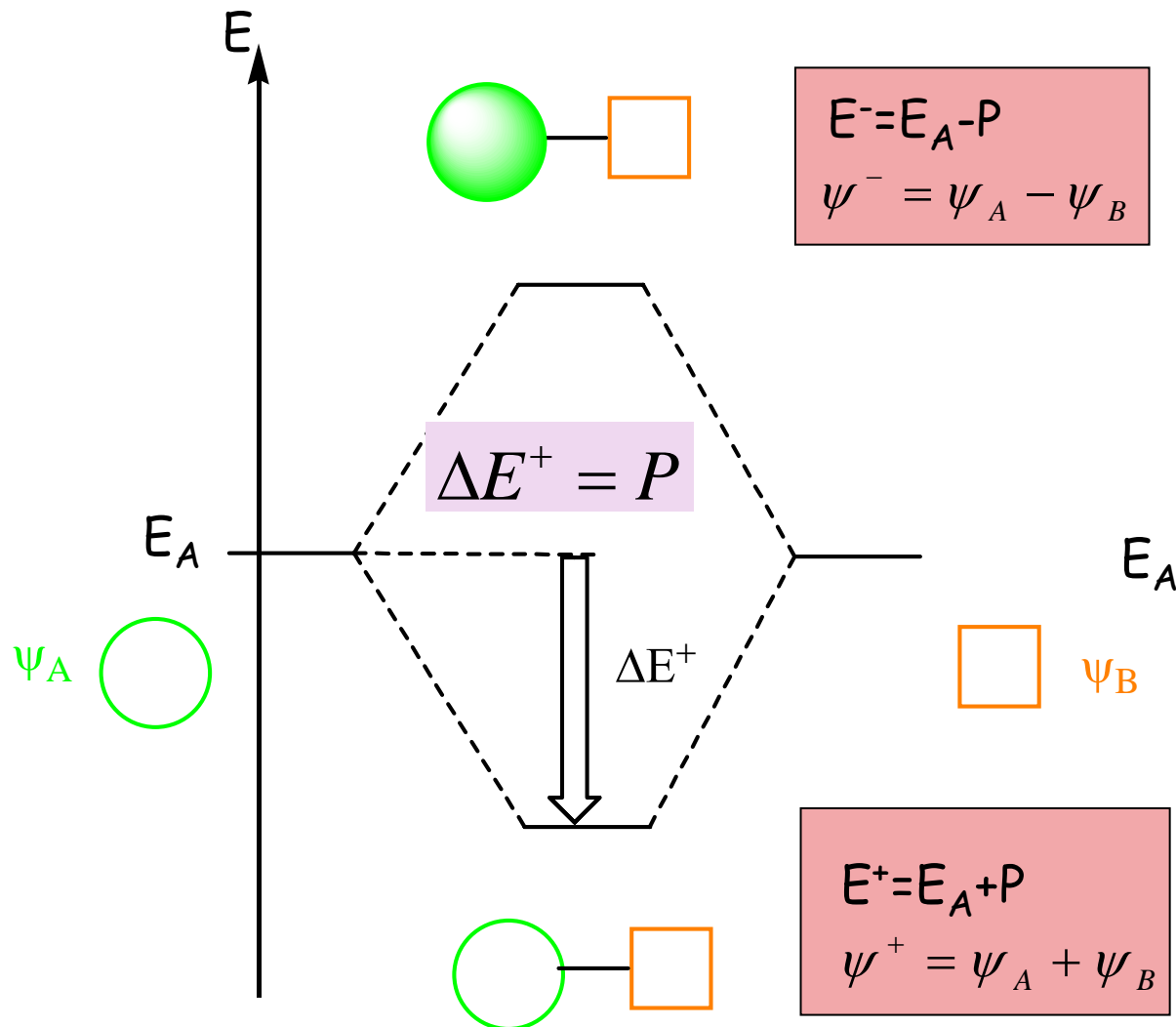

# Cas de deux OM non dégénérées

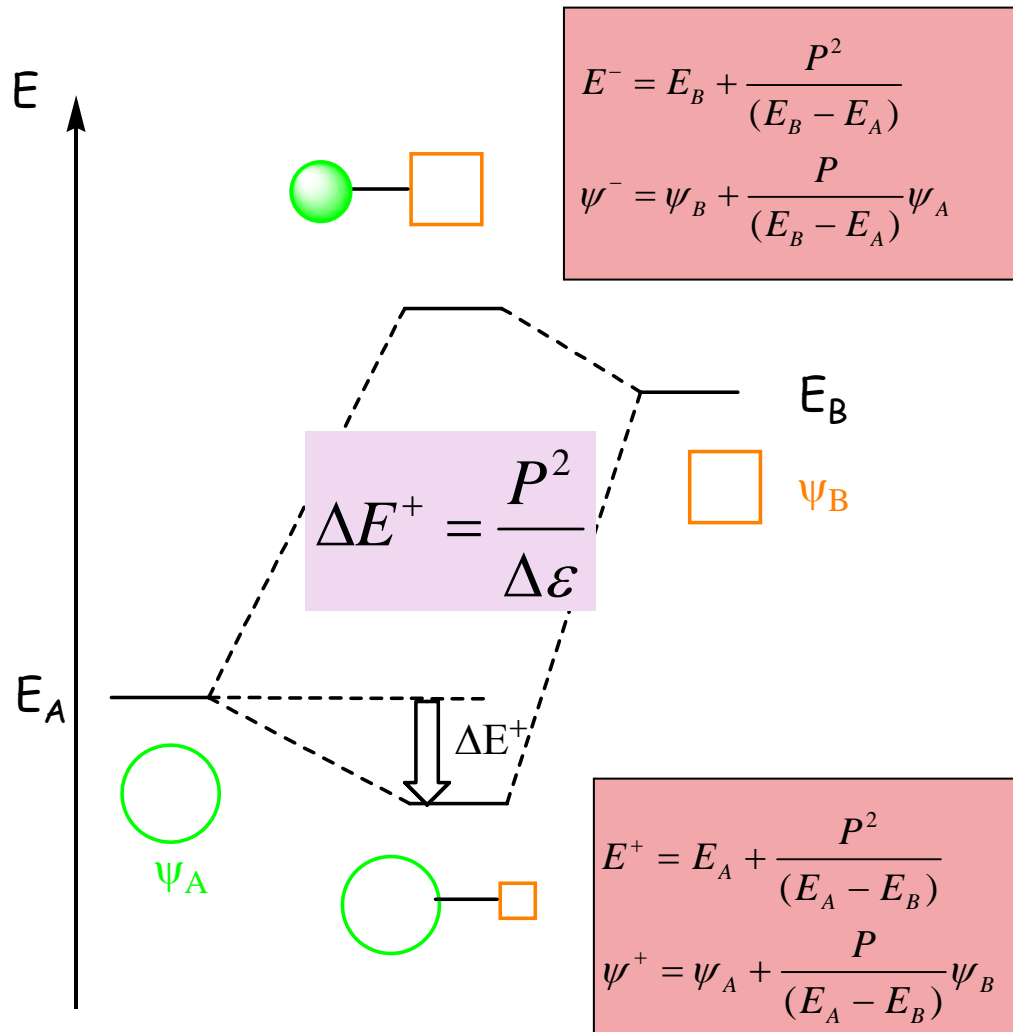

# Calcul de P

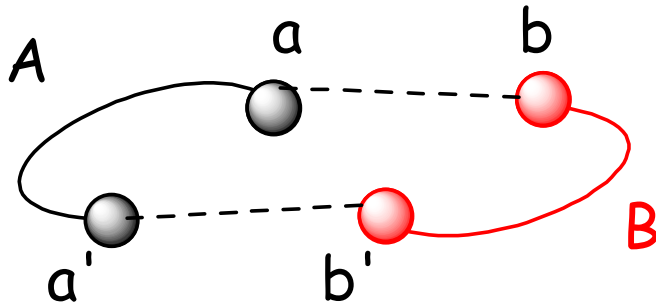

$$P = c_a c_b \beta_{ab} + c_{a'} c_{b'} \beta_{a'b'}$$

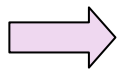

$P < 0$  si recouvrement en phase

$P = 0$  si OM  $\psi_A$  et  $\psi_B$  orthogonales

# Calcul de P

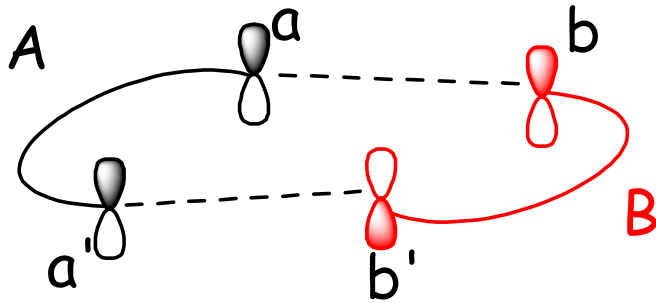

$$P = 0$$

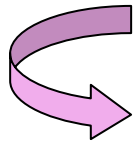

Analyse des symétries du système

# Extension

$$|E_A - E_B| > |P| \quad E = E_{\text{perturbée}} + \frac{P^2}{(E_{\text{perturbée}} - E_{\text{perturbatrice}})}$$

$$\psi = \psi_{\text{perturbée}} + \frac{P}{(E_{\text{perturbée}} - E_{\text{perturbatrice}})} \psi_{\text{perturbatrice}}$$

$|P| \geq |E_A - E_B|$   $\rightarrow$  cas OM dégénérées

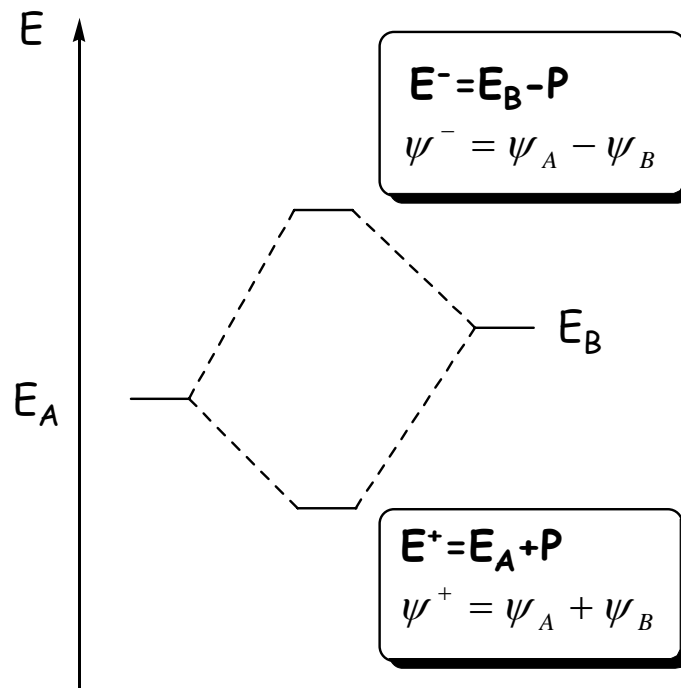

# Plan du cours

---

La théorie des perturbations : rappel

Un exemple : le propène

La réactivité : modélisation

Application aux cycloadditions

# Application : le propène

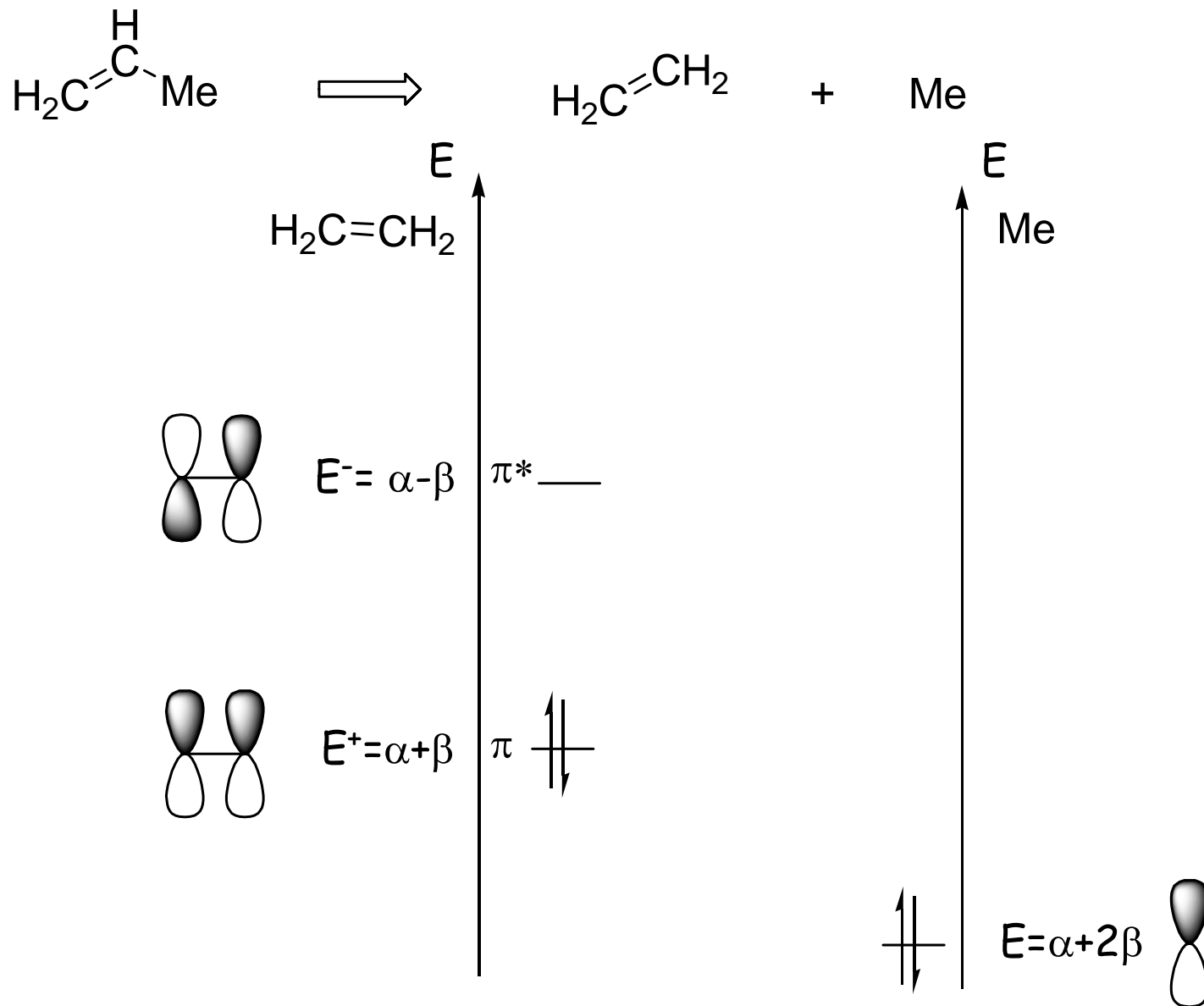

# Perturbation $\pi/Me$

Calcul de  $P_{\pi/Me}$

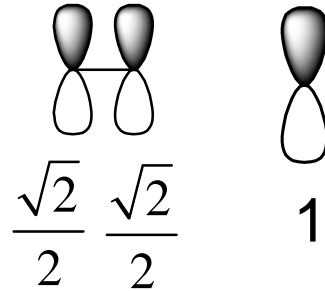

$$P_{\pi/Me} = \frac{\sqrt{2}}{2} \times 1 \times \beta_{C-Me} = \frac{\sqrt{2}}{2} \times 0,7\beta \approx 0,5\beta$$

$$\Delta E_{\pi/Me} = (\alpha + 2\beta) - (\alpha + \beta) = \beta$$

$$|P_{\pi/Me}| \ll |\Delta E_{\pi/Me}| \implies \text{Cas de 2 OM non dégénérées}$$

# Perturbation $\pi^*/Me$

Calcul de  $P_{\pi^*/Me}$

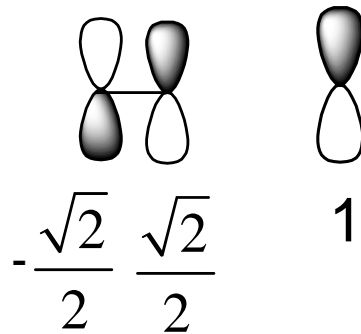

$$P_{\pi^*/Me} = \frac{\sqrt{2}}{2} \times 1 \times \beta_{C-Me} = \frac{\sqrt{2}}{2} \times 0,7\beta \approx 0,5\beta$$

$$\Delta E_{\pi^*/Me} = (\alpha + 2\beta) - (\alpha - \beta) = 3\beta$$

$$|P_{\pi^*/Me}| < |\Delta E_{\pi^*/Me}| \implies \text{Cas de 2 OM non dégénérées}$$

# Application : le propène

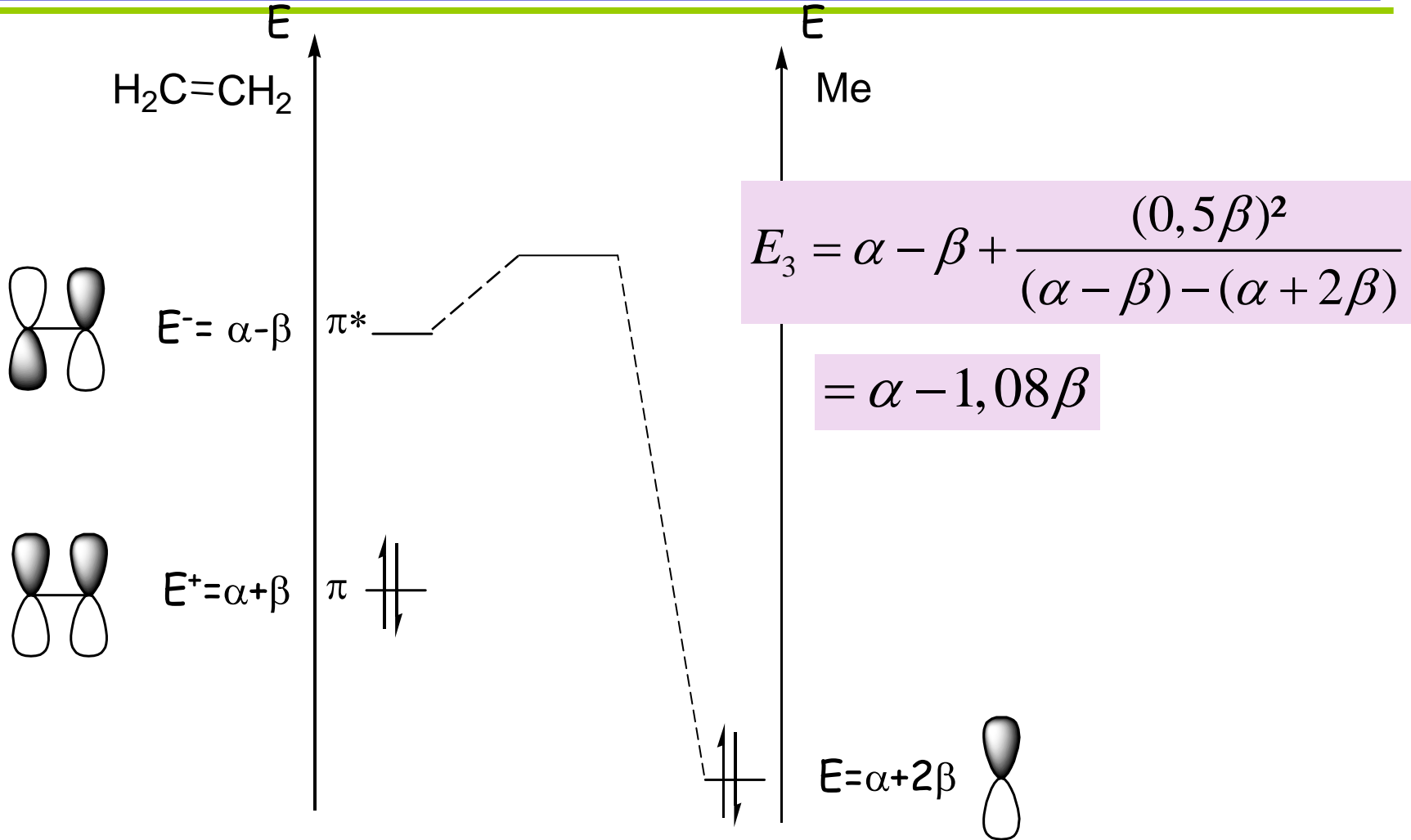

# Application : le propène

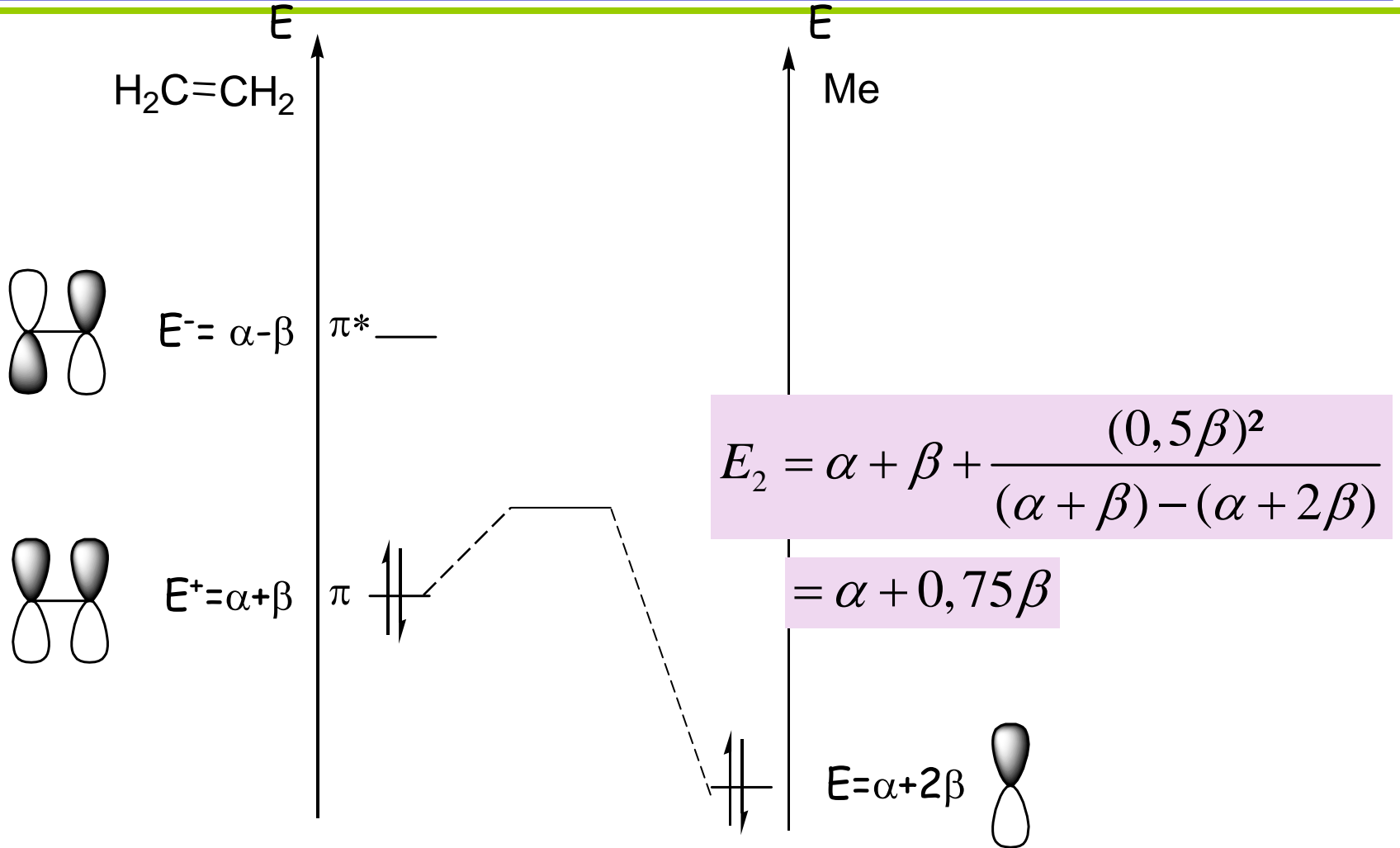

# Application : le propène

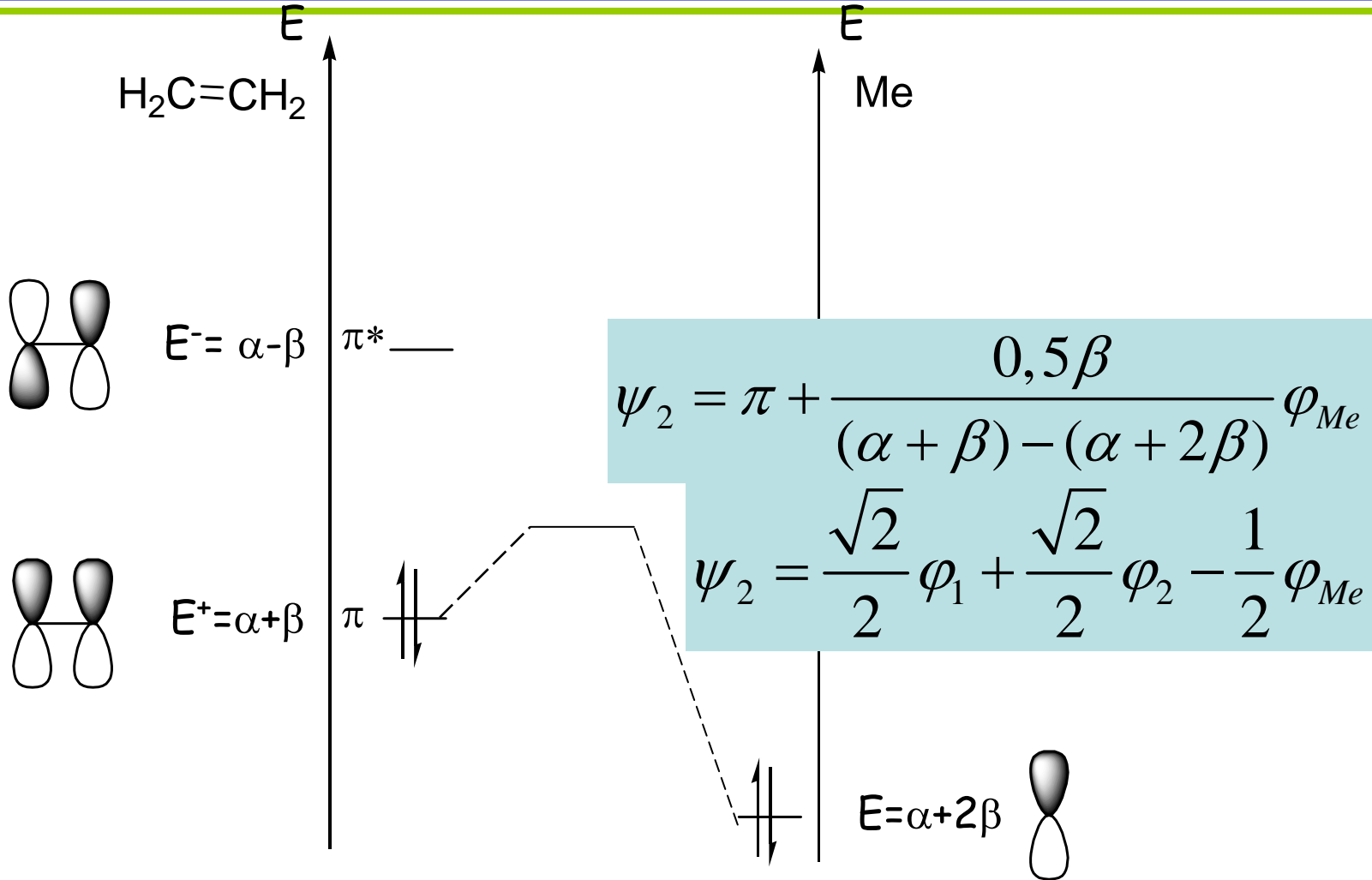

# Application : le propène

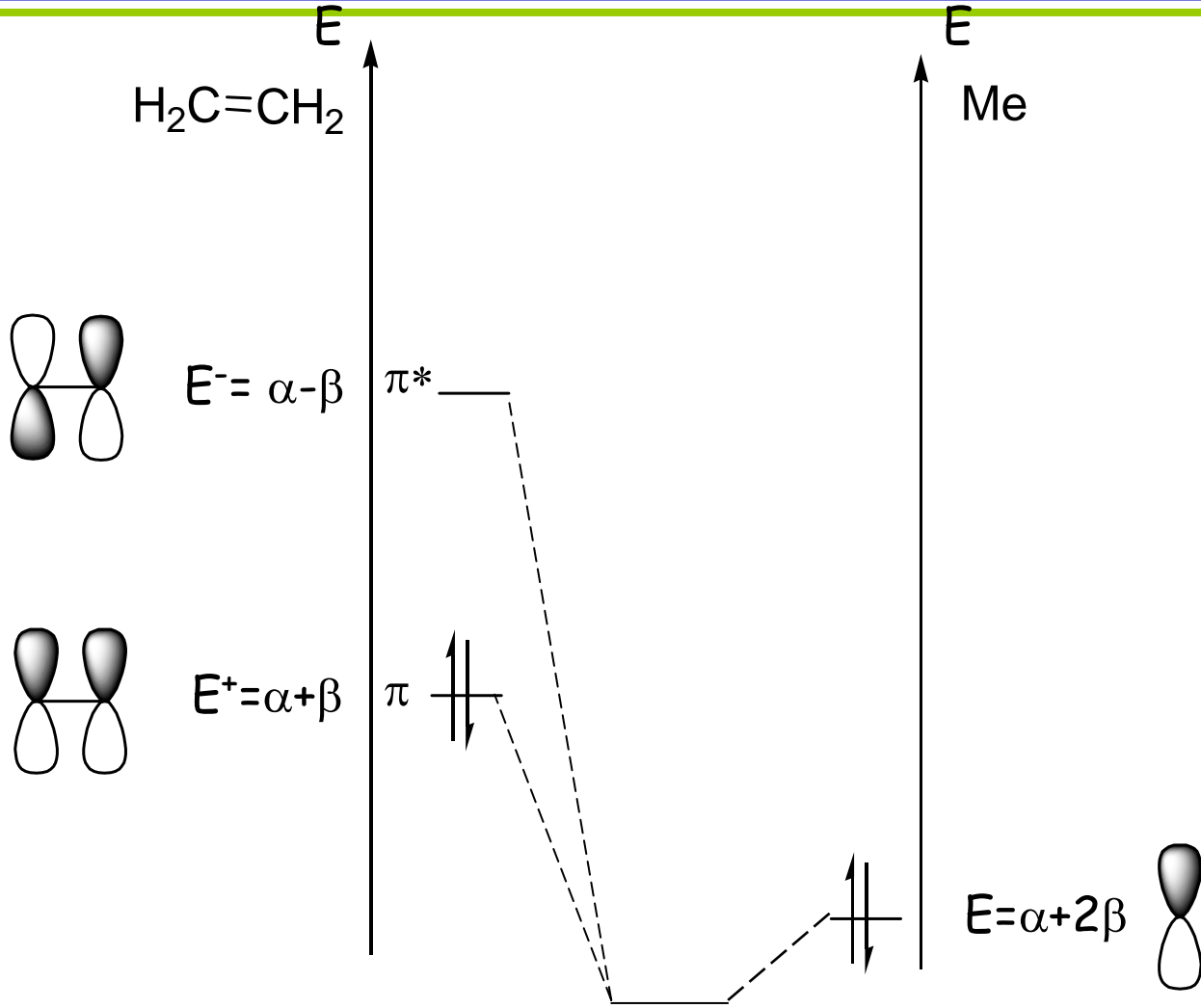

$$E_1 = \alpha + 2\beta + \frac{(0,5\beta)^2}{(\alpha + 2\beta) - (\alpha + \beta)} + \frac{(0,5\beta)^2}{(\alpha + 2\beta) - (\alpha - \beta)}$$

# Application : le propène

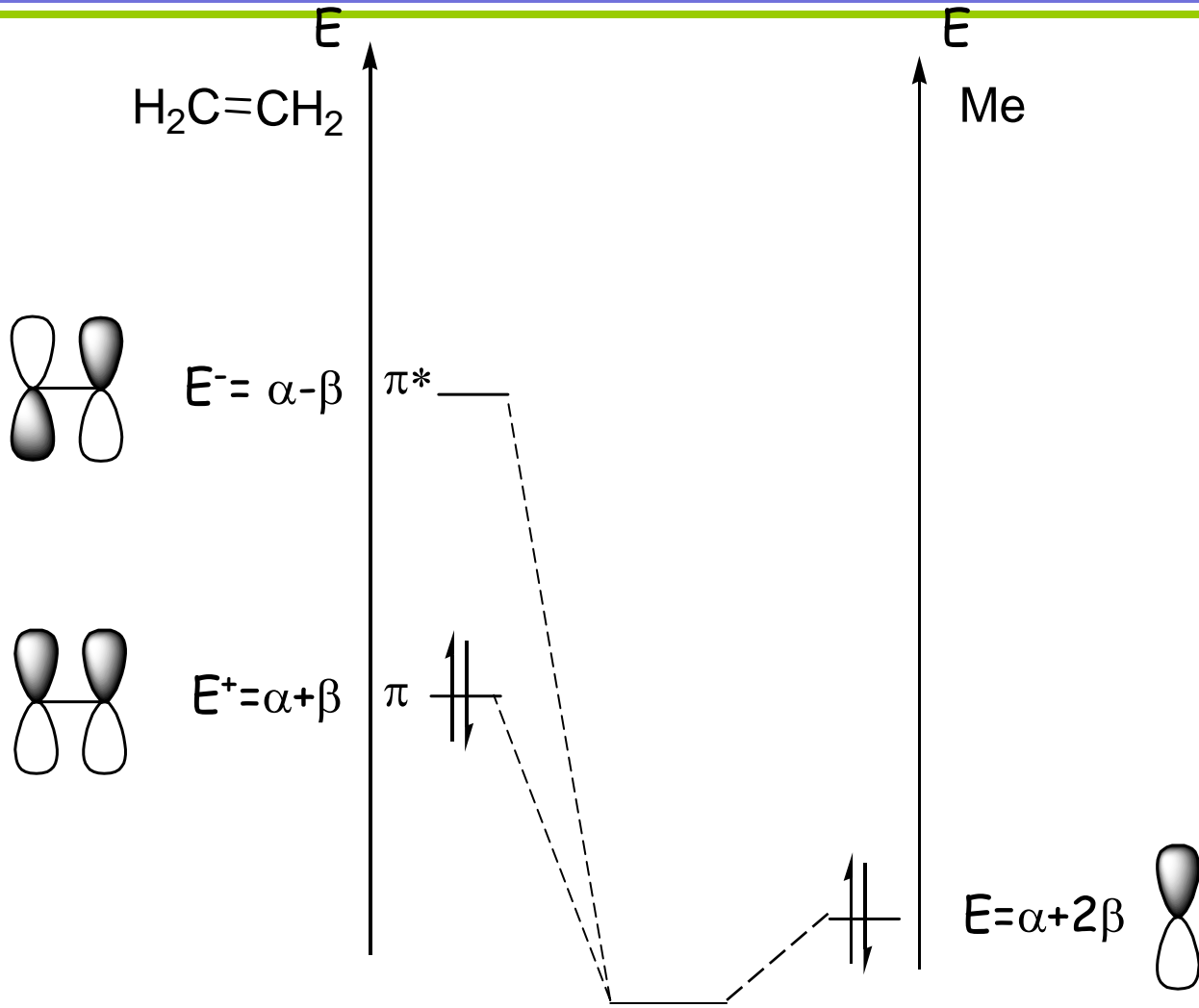

$$E_1 = \alpha + 2,33\beta$$

# Application : le propène

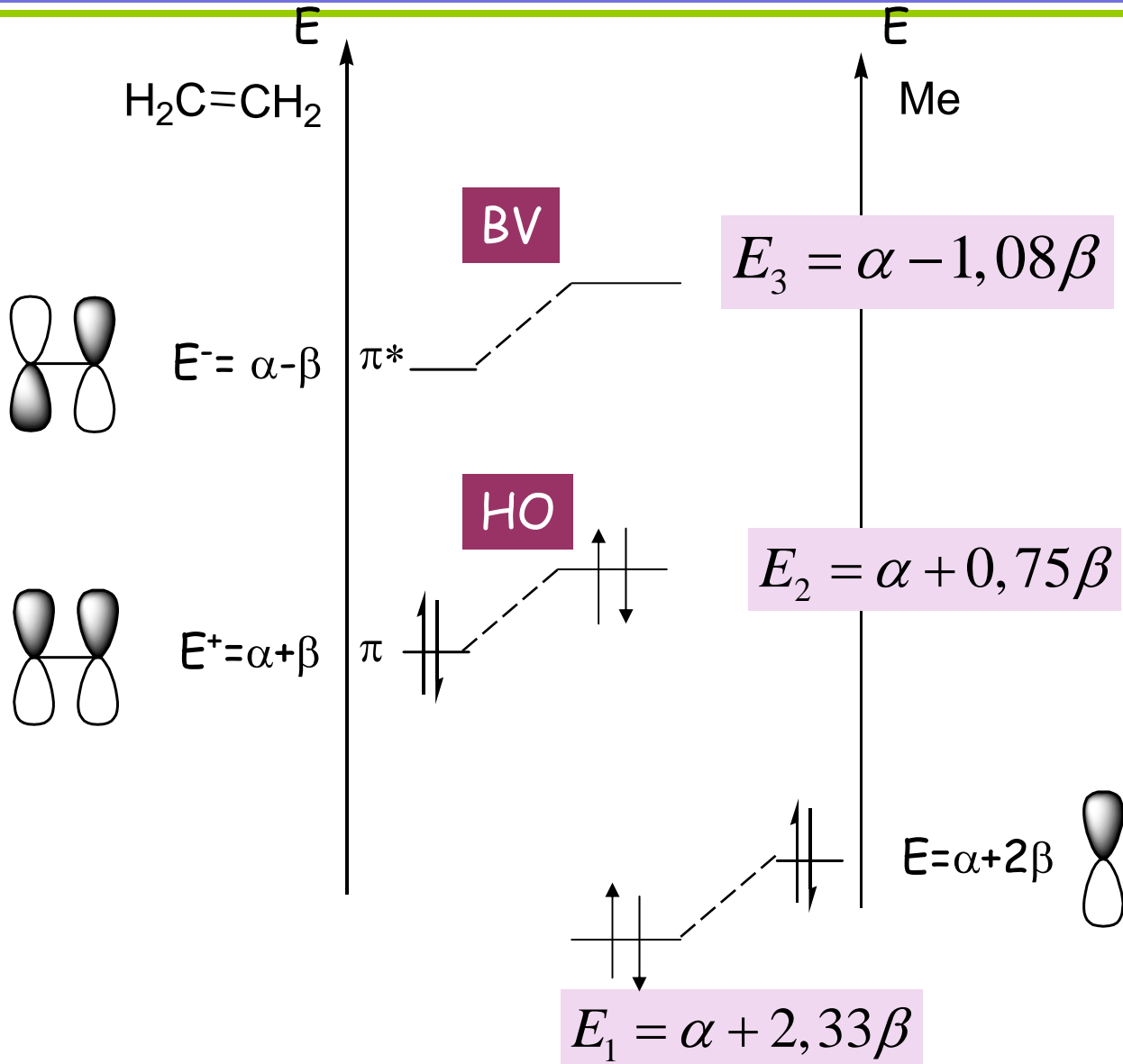

# Généralisation

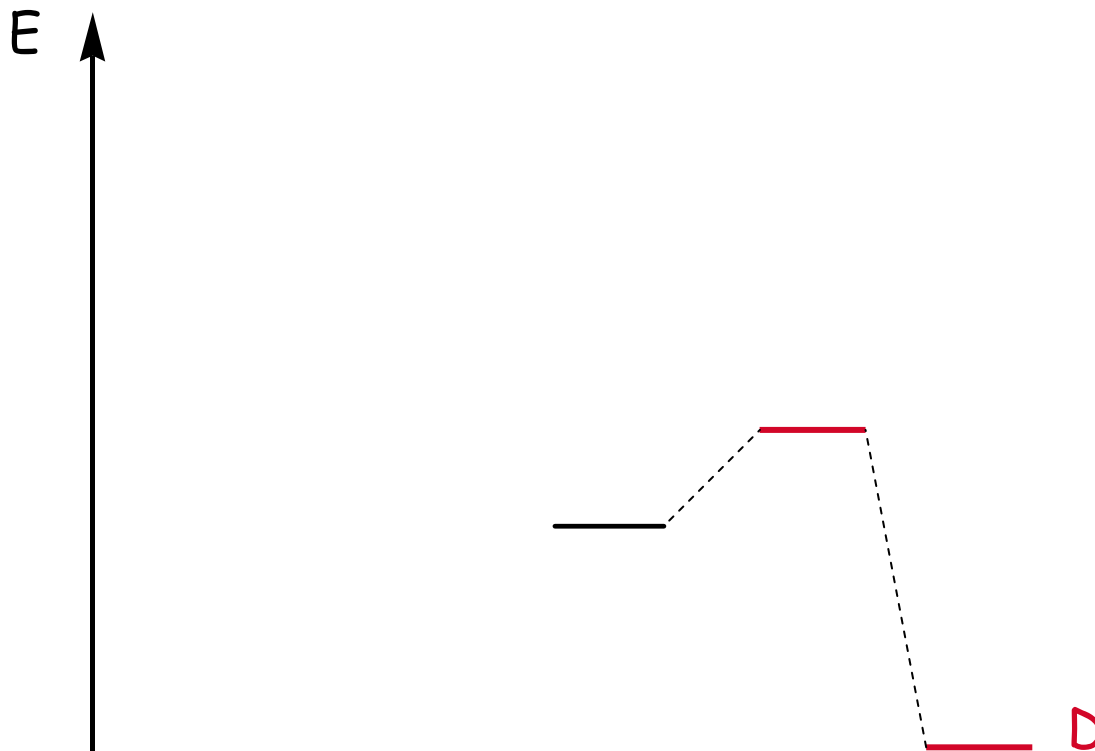

La perturbation par un groupe donneur augmente l'énergie de l'OM perturbée

# Généralisation

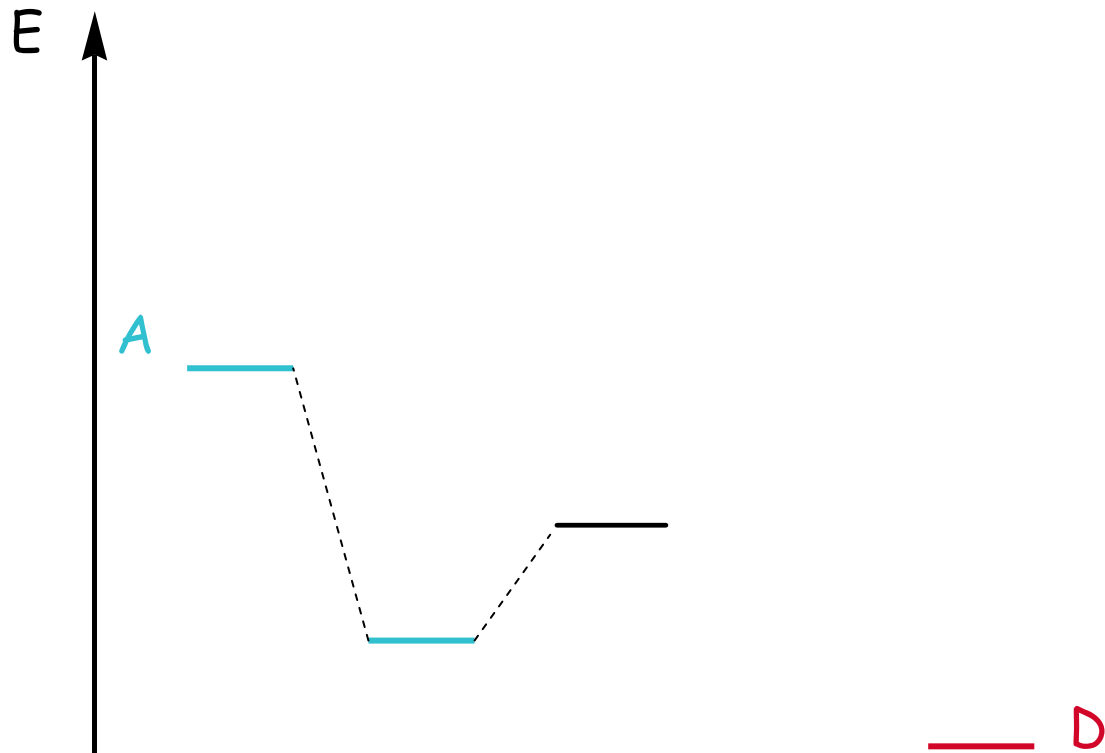

La perturbation par un groupe accepteur abaisse l'énergie de l'OM perturbée

# Plan du cours

---

La théorie des perturbations : rappel

Un exemple : le propène

La réactivité : modélisation

Application aux cycloadditions

# Réactivité

Comment prévoir et modéliser la réactivité ?



Contrôle thermodynamique



Contrôle cinétique

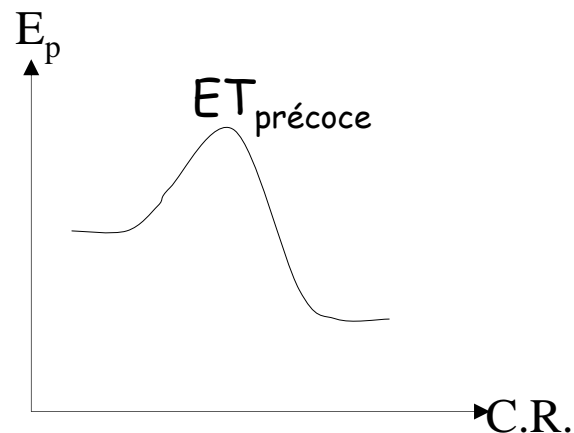
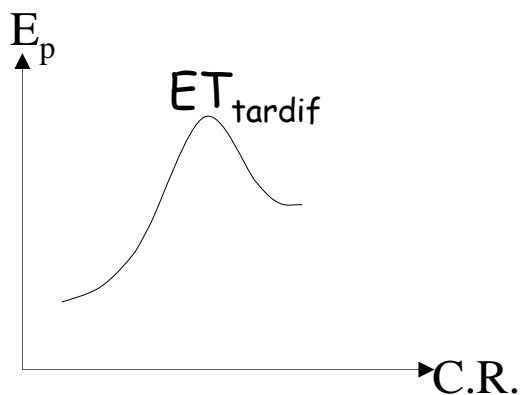

# Contrôle cinétique - ET précoce

---

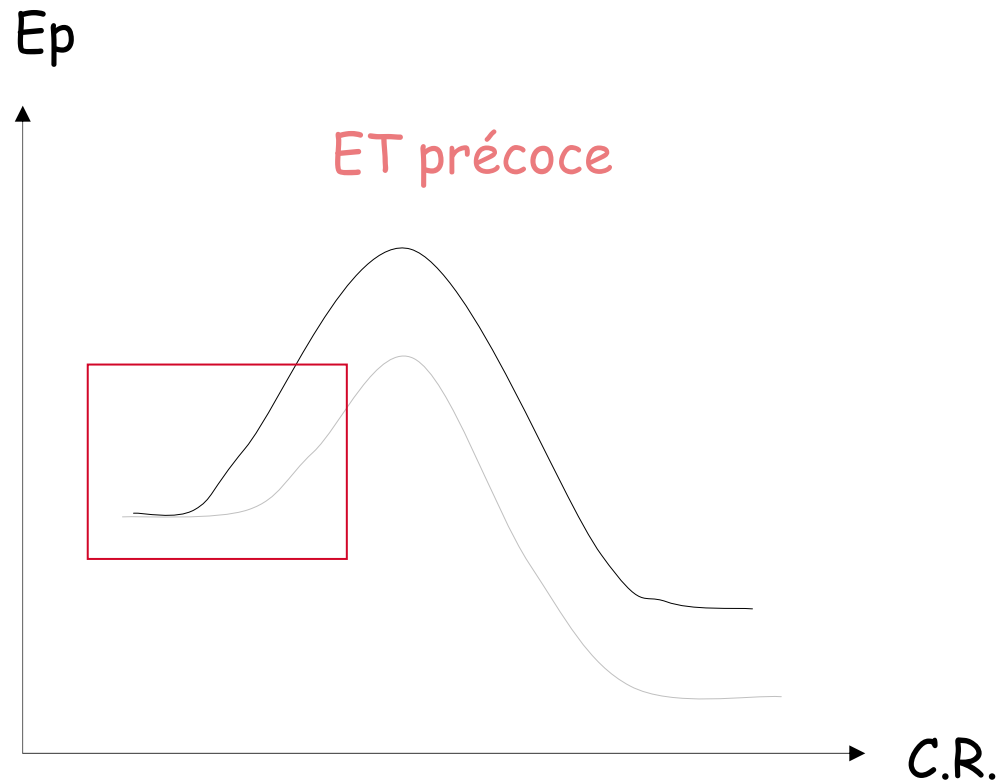

Analyse des différents facteurs

# Interactions à considérer

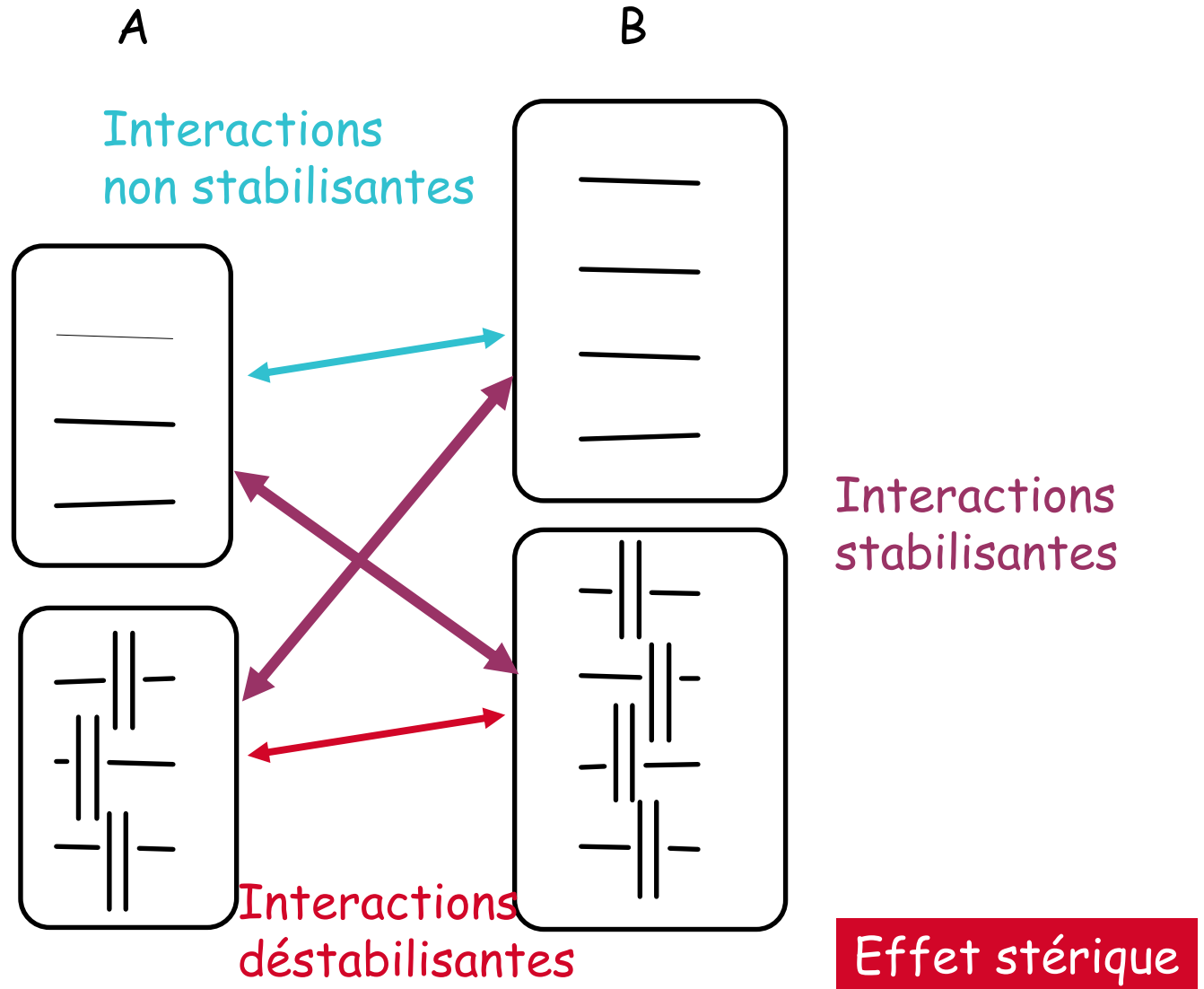

# Interactions à considérer

---

Influence du solvant *souvent faible*

Interactions coulombiennes *pour les espèces chargées*

Terme de transfert électronique dû au *recouvrement orbitalaire*

# Orbitales frontières

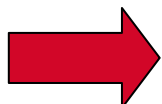
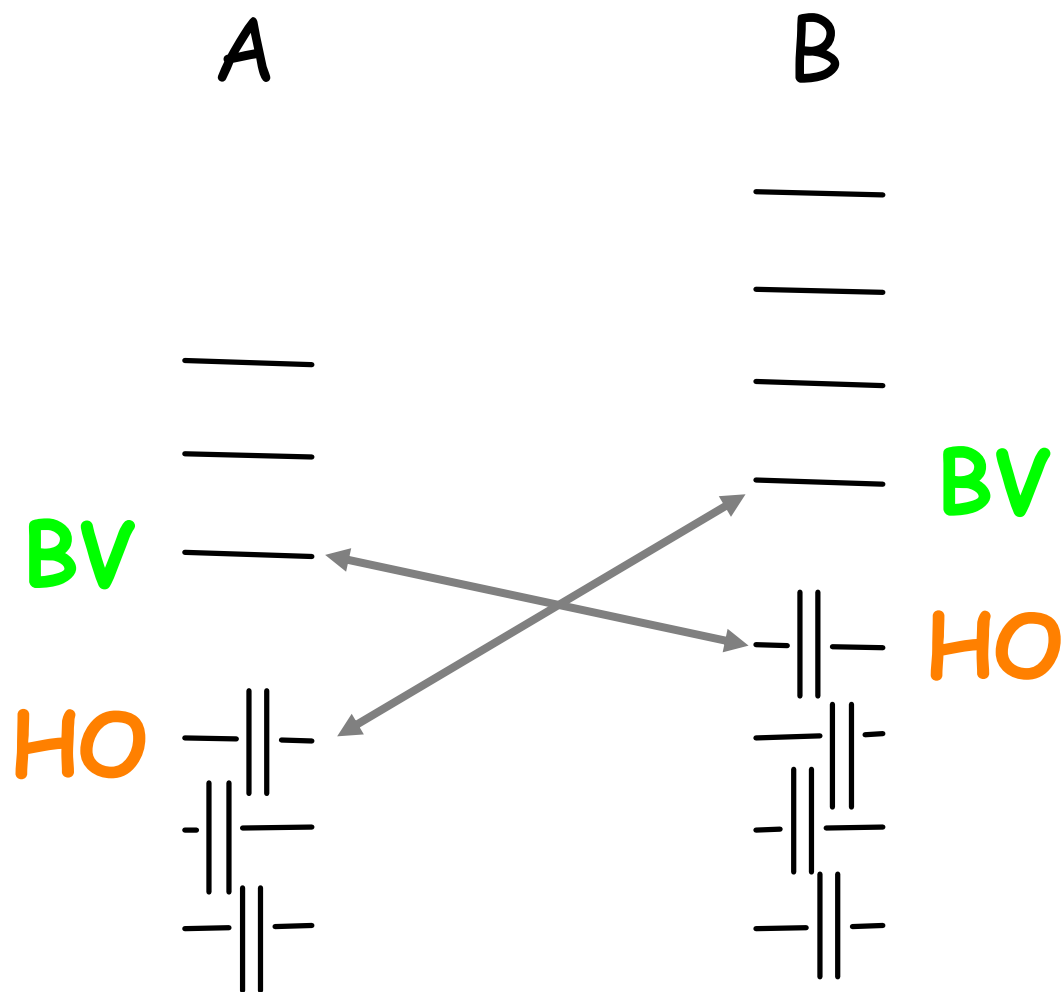

Approximation de Fukui

# Orbitales frontières

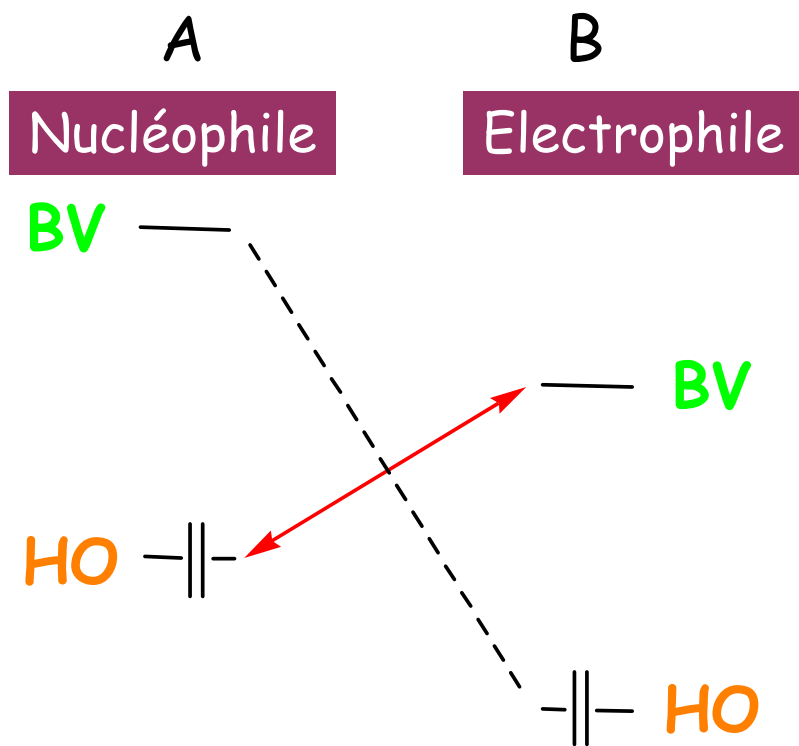

**interaction principale**

Nucléophile = donneur d'électrons

Electrophile = accepteur d'électrons

# Application : le propène

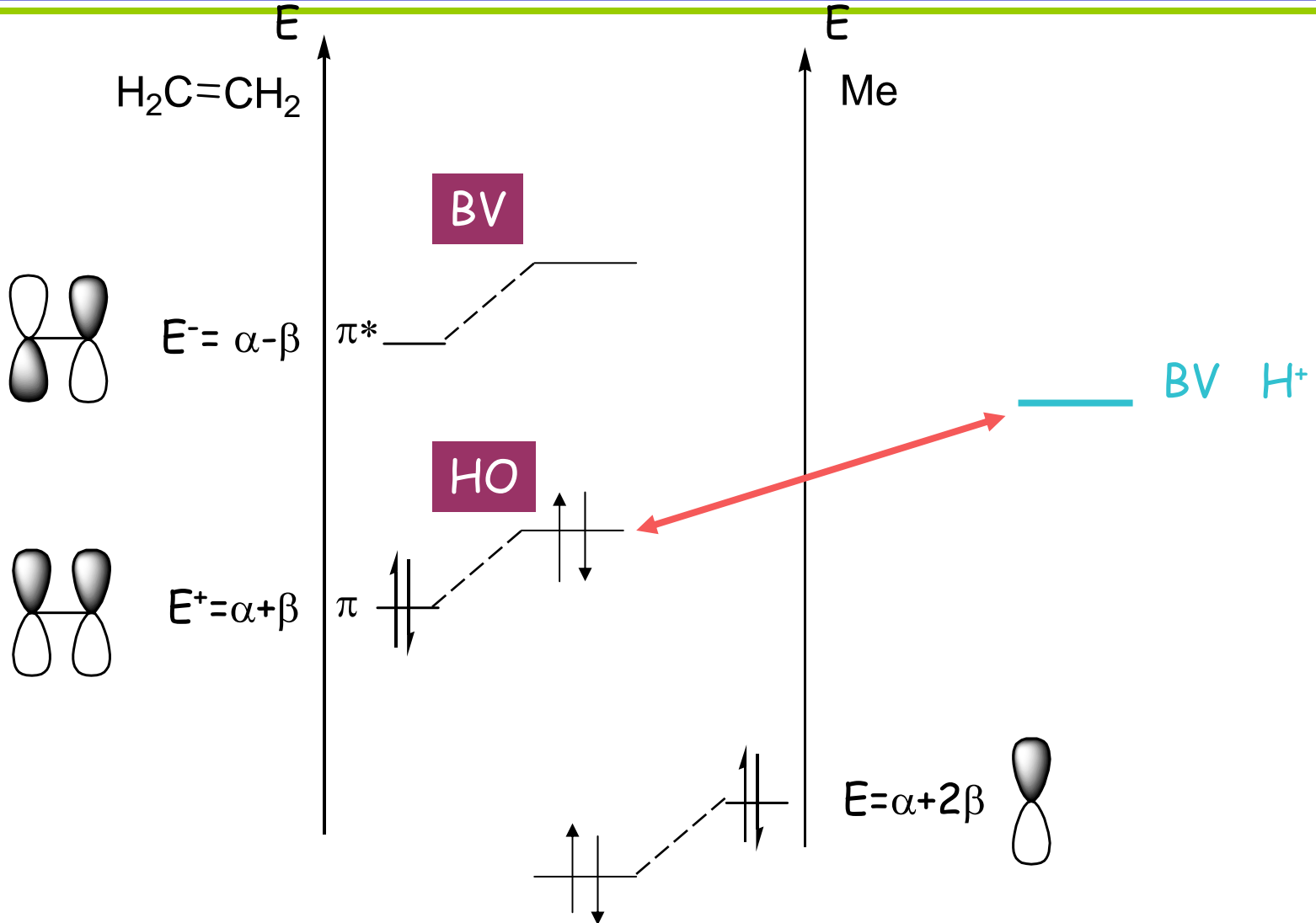

➔ Propène plus réactif vis-à-vis de  $H^+$  que l'éthylène

# Plan du cours

---

La théorie des perturbations : rappel

Un exemple : le propène

La réactivité : modélisation

Application aux cycloadditions

# Cycloadditions : définition

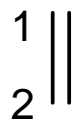

+

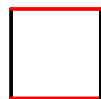
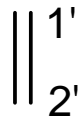

cycloaddition [2+2]

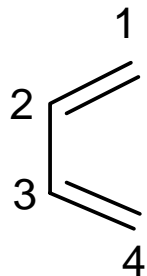

+

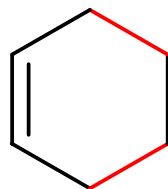
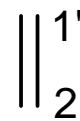

cycloaddition [4+2]

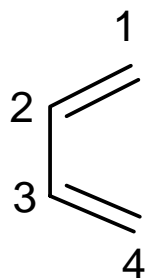

+

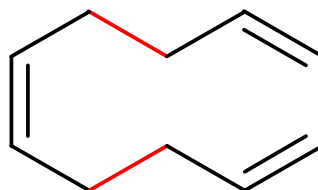
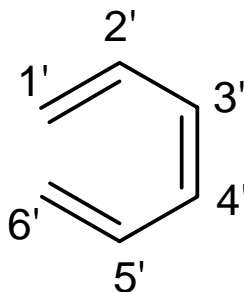

cycloaddition [4+6]

# Réaction de Diels-Alder

